

SFF Committee documentation may be purchased in hard copy or electronic form
SFF Committee documents are available at <ftp://ftp.t13.org/unafiliated/sff>

SFF Committee

SFF-8120 Specification for

Parallel 1.8" drive form factor (78x54mm)

Rev 2.6 August 31, 2001

Secretariat: SFF Committee

Abstract: This document defines the dimensions for 1.8" magnetic disk drives which have a parallel interface and operate at 3.3V.

This document provides a common specification for systems manufacturers, system integrators, and suppliers of magnetic disk drives. This is an internal working document of the SFF Committee, an industry ad hoc group.

This document is made available for public review, and written comments are solicited from readers. Comments received by the members will be considered for inclusion in future revisions of this document.

The description of a connector in this document does not assure that the specific component is actually available from connector suppliers. If such a connector is supplied it must comply with this specification to achieve interoperability between suppliers.

Support: This document is supported by the identified member companies of the SFF Committee.

Documentation: This document has been prepared in a similar style to that of the ISO (International Organization of Standards).

POINTS OF CONTACT:

Tasuku Kasebayashi
Technical Editor
TOSHIBA AMERICA
35 Hammond
Irvine CA 92618

I. Dal Allan
Chairman SFF Committee
14426 Black Walnut Court
Saratoga
CA 95070

949-461-3886
949-458-7815Fx
task.kasebayashi@taec.toshiba.com

408-867-6630
408-867-2115Fx
endlcom@acm.org

EXPRESSION OF SUPPORT BY MANUFACTURERS

The following member companies of the SFF Committee voted in favor of this industry specification.

DDK Fujikura
EMC
ENDL
FCI/Berg
Hitachi Cable
IBM
Maxtor
Seagate
Toshiba America
Tyco AMP

The following member companies of the SFF Committee voted to abstain on this industry specification.

Circuit Assembly
Compaq
Fujitsu CPA
Intel
Molex
Picolight
Unisys

To save space for SFF Specifications being reviewed, the information on the principles of the SFF Committee and how to join has not been printed.

SFF Committee --

Parallel 1.8" drive form factor (78x54mm)

1. Scope

The 81xx suite of specifications defines the configuration characteristics associated with 1.8" disk drives.

The purpose of the 81xx suite is to define the external characteristics of drives such that products from different vendors may be used in the same mounting configurations. The set of specifications provide external dimensions, connectors, connector placement, mounting holes and interface pinouts to assist manufacturers in the systems integration of small form factor disk drives.

- SFF-8111 defines a 60x70mm 1.8" form factor drive with a parallel interface operating at 5V
- SFF-8120 defines a 78x54mm 1.8" form factor drive with a parallel interface operating at 3.3V

In an effort to broaden the applications for storage devices, an ad hoc industry group of companies representing system integrators, peripheral suppliers, and component suppliers decided to address the issues involved.

The SFF Committee was formed in August, 1990 and the first working document was introduced in January, 1991.

1.1 Description of Clauses

Clause 1 contains the Scope and Purpose.

Clause 2 contains Referenced and Related Standards and SFF Specifications.

Clause 3 begins the specification

2. References

The SFF Committee activities support the requirements of the storage industry, and it is involved with several standards.

2.1 Industry Documents

The following interface standards are relevant to this Specification.

- T13/D1321 ATA-5 ATA/ATAPI-5
- T13/D1410 ATA-6 ATA/ATAPI-6

2.2 SFF Specifications

There are several projects active within the SFF Committee. At the date of printing document numbers had been assigned to the following projects. The status of Specifications is dependent on committee activities.

- F = Forwarded The document has been approved by the members for forwarding to a formal standards body.
- P = Published The document has been balloted by members and is

	available as a published SFF Specification.
A = Approved	The document has been approved by ballot of the members and is in preparation as an SFF Specification.
C = Canceled	The project was canceled, and no Specification was Published.
D = Development	The document is under development at SFF.
E = Expired	The document has been published as an SFF Specification, and the members voted against re-publishing it when it came up for annual review.
e = electronic	Used as a suffix to indicate an SFF Specification which has Expired but is still available in electronic form from SFF e.g. a specification has been incorporated into a draft or published standard which is only available in hard copy.
i = Information	The document has no SFF project activity in progress, but it defines features in developing industry standards. The document was provided by a company, editor of an accredited standard in development, or an individual. It is provided for broad review (comments to the author are encouraged).
s = submitted	The document is a proposal to the members for consideration to become an SFF Specification.

Spec # Rev List of Specifications as of August 31, 2001

SFF-8000		SFF Committee Information
INF-8001i	E	44-pin ATA (AT Attachment) Pinouts for SFF Drives
INF-8002i	E	68-pin ATA (AT Attachment) for SFF Drives
SFF-8003	E	SCSI Pinouts for SFF Drives
SFF-8004	E	Small Form Factor 2.5" Drives
SFF-8005	E	Small Form Factor 1.8" Drives
SFF-8006	E	Small Form Factor 1.3" Drives
SFF-8007	E	2mm Connector Alternatives
SFF-8008	E	68-pin Embedded Interface for SFF Drives
SFF-8009	4.1	Unitized Connector for Cabled Drives
SFF-8010	E	Small Form Factor 15mm 1.8" Drives
INF-8011i	E	ATA Timing Extensions for Local Bus
SFF-8012	3.0	4-Pin Power Connector Dimensions
SFF-8013	E	ATA Download Microcode Command
SFF-8014	C	Unitized Connector for Rack Mounted Drives
SFF-8015	E	SCA Connector for Rack Mounted SFF SCSI Drives
SFF-8016	C	Small Form Factor 10mm 2.5" Drives
SFF-8017	E	SCSI Wiring Rules for Mixed Cable Plants
SFF-8018	E	ATA Low Power Modes
SFF-8019	E	Identify Drive Data for ATA Disks up to 8 GB
INF-8020i	E	ATA Packet Interface for CD-ROMs
INF-8028i	E	- Errata to SFF-8020 Rev 2.5
SFF-8029	E	- Errata to SFF-8020 Rev 1.2
SFF-8030	1.8	SFF Committee Charter
SFF-8031		Named Representatives of SFF Committee Members
SFF-8032	1.4	SFF Committee Principles of Operation
INF-8033i	E	Improved ATA Timing Extensions to 16.6 MBs
INF-8034i	E	High Speed Local Bus ATA Line Termination Issues
INF-8035i	E	Self-Monitoring, Analysis and Reporting Technolog
INF-8036i	E	ATA Signal Integrity Issues

INF-8037i	E	Intel Small PCI SIG
INF-8038i	E	Intel Bus Master IDE ATA Specification
INF-8039i	E	Phoenix EDD (Enhanced Disk Drive) Specification
SFF-8040	1.2	25-pin Asynchronous SCSI Pinout
SFF-8041	C	SCA-2 Connector Backend Configurations
SFF-8042	C	VHDCI Connector Backend Configurations
SFF-8043	E	40-pin MicroSCSI Pinout
SFF-8045	4.5	40-pin SCA-2 Connector w/Parallel Selection
SFF-8046	E	80-pin SCA-2 Connector for SCSI Disk Drives
SFF-8047	C	40-pin SCA-2 Connector w/Serial Selection
SFF-8048	C	80-pin SCA-2 Connector w/Parallel ESI
SFF-8049	E	80-conductor ATA Cable Assembly
INF-8050i	1.0	Bootable CD-ROM
INF-8051i	E	Small Form Factor 3" Drives
INF-8052i	E	ATA Interface for 3" Removable Devices
SFF-8053	5.5	GBIC (Gigabit Interface Converter)
INF-8055i	E	SMART Application Guide for ATA Interface
SFF-8056	C	50-pin 2mm Connector
SFF-8057	E	Unitized ATA 2-plus Connector
SFF-8058	E	Unitized ATA 3-in-1 Connector
SFF-8059	E	40-pin ATA Connector
SFF-8060	1.1	SFF Committee Patent Policy
SFF-8061	1.1	Emailing drawings over the SFF Reflector
SFF-8062		Rolling Calendar of SSWGs and Plenaries
SFF-8065	C	40-pin SCA-2 Connector w/High Voltage
SFF-8066	C	80-pin SCA-2 Connector w/High Voltage
SFF-8067	2.9	40-pin SCA-2 Connector w/Bidirectional ESI
INF-8068i	1.0	Guidelines to Import Drawings into SFF Specs
SFF-8069	E	Fax-Access Instructions
INF-8070i	1.3	ATAPI for Rewritable Removable Media
SFF-8072	1.2	80-pin SCA-2 for Fibre Channel Tape Applications
SFF-8073	-	20-pin SCA-2 for GBIC Applications
INF-8074i	1.0	SFP (Small Formfactor Pluggable) Transceiver
SFF-8075	1.0	PCI Card Version of SFP Cage
SFF-8080	E	ATAPI for CD-Recordable Media
INF-8090i	5.3	ATAPI for DVD (Digital Video Data)
SFF-8101		3 Gbs and 4 Gbs Signal Characteristics
SFF-8110	C	5V Parallel 1.8" drive form factor
SFF-8111	1.2	1.8" drive form factor (60x70mm)
SFF-8120	2.6	1.8" drive form factor (78x54mm)
SFF-8200e	1.1	2 1/2" drive form factors (all of 82xx family)
SFF-8201e	1.3	2 1/2" drive form factor dimensions
SFF-8212e	1.2	2 1/2" drive w/SFF-8001 44-pin ATA Connector
SFF-8300e	1.1	3 1/2" drive form factors (all of 83xx family)
SFF-8301e	1.2	3 1/2" drive form factor dimensions
SFF-8302e	1.1	3 1/2" Cabled Connector locations
SFF-8332e	1.2	3 1/2" drive w/80-pin SFF-8015 SCA Connector
SFF-8337e	1.2	3 1/2" drive w/SCA-2 Connector
SFF-8342e	1.3	3 1/2" drive w/Serial Unitized Connector
INF-8350i	6.1	3 1/2" Packaged Drives

SFF-8400	C	VHDCI (Very High Density Cable Interconnect)
SFF-8410	16.1	High Speed Serial Testing for Copper Links
SFF-8411		High Speed Serial Testing for Backplanes
SFF-8412	3.1	HSS Requirements for Duplex Optical Links
SFF-8415	1.1	HPEI (High Performance Electrical Interconnect)
SFF-8416		HSS Bulk Cable Performance Requirements
SFF-8420	11.1	HSSDC-1 Shielded Connections
SFF-8421	2.1	HSSDC-2 Shielded Connections
SFF-8422	C	FCI Shielded Connections
SFF-8423	C	Molex Shielded Connections
SFF-8430	4.1	MT-RJ Duplex Optical Connections
SFF-8441	14.1	VHDCI Shielded Configurations
SFF-8451	10.1	SCA-2 Unshielded Connections
SFF-8452	3.1	Glitch Free Mating Connections for Multidrop Aps
SFF-8460	1.1	HSS Backplane Design Guidelines
SFF-8470	1.0	Multi Lane Copper Connector
SFF-8472	3.1	Diagnostic Monitoring Interface for Optical Xcvrs
SFF-8480	2.1	HSS (High Speed Serial) DB9 Connections
SFF-8500e	1.1	5 1/4" drive form factors (all of 85xx family)
SFF-8501e	1.1	5 1/4" drive form factor dimensions
SFF-8508e	1.1	5 1/4" ATAPI CD-ROM w/audio connectors
SFF-8551	3.2	5 1/4" CD Drives form factor
SFF-8572	-	5 1/4" Tape form factor
SFF-8610	C	SDX (Storage Device Architecture)

2.3 Sources

Copies of ANSI standards or proposed ANSI standards may be purchased from Global Engineering.

15 Inverness Way East	800-854-7179 or 303-792-2181
Englewood	303-792-2192Fx
CO 80112-5704	

Copies of SFF Specifications are available by joining the SFF Committee as an Observer or Member.

14426 Black Walnut Ct	408-867-6630x303
Saratoga	408-867-2115Fx
CA 95070	FaxAccess: 408-741-1600

The increasing size of SFF Specifications has made FaxAccess impractical to obtain large documents. Document subscribers and members are automatically updated every two months with the latest specifications. Specifications are available by FTP at <ftp.t13.org/Unaffiliated/sff>

Electronic copies of documents are also made available via CD_Access, a service which provides copies of all the specifications plus SFF reflector traffic. CDs are mailed every 2 months as part of the document service, and provide the letter ballot and paper copies of what was distributed at the meeting as well as the meeting minutes.

ELECTRONIC COPIES

The status of SFF Specifications is summarized in SFF-8000, which is the only specification which can now be obtained over FaxAccess.

Document subscribers and members are automatically updated every two months with the latest specifications.

Please register me as a Member of the SFF Committee for one year.

Paper documentation \$1,800

Electronic documentation \$2,160

Check Payable to SFF Committee for \$_____ is Enclosed

Please invoice me \$_____ on PO #: _____

MC/Visa/AmX _____ Expires _____

Please register me as an Observer on the SFF Committee for one year.

Paper documentation \$ 300 U.S. \$400 Overseas

Electronic documentation \$ 660 U.S. \$760 Overseas

Check Payable to SFF Committee for \$_____ (POs Not Accepted)

MC/Visa/AmX _____ Expires _____

Name _____ Company _____

Address _____

State/ZIP _____ Email _____

Phone _____ Fax _____

SFF Committee	408-867-6630
14426 Black Walnut Ct	408-867-2115Fx
Saratoga CA 95070	250-1752@mcimail.com
Transfers to Bank of America:	04743 00743

Document subscribers and members are automatically updated every two months with the latest specifications. Specifications are also available by FTP at ftp.t13.org/unafililiated/sff

3. General Description

The application environment for small form factor disks is any computer connecting to one or more disks in a restricted packaging environment.

The purpose of an SFF Specification is to provide information that will assist vendors to design products that can fit the same packaging envelope.

Small form factor disks are widely used where low power and small size are important configuration parameters.

4. 1.8" Disk Drive Physical Configuration

4.1 Cooling Airflow

Except at the attachment area, 0.75mm clearance around the drive is recommended for cooling airflow.

4.2 Physical Dimensions

This document contains the general drive dimensional information that applies to the 1.8" disk drives.

The drive shall be measured at 20 +/- 2 degrees C. The drive shall not be exposed to any conditions (transit temperatures, shock, etc.) beyond the manufacturer's specified limits before measurement.

5. Mounting Considerations

Mounting area is shown in Figure 7-1.

1.8" drive shall be guided or fixed by the interconnect or mounting area.

6. Power and Grounding

6.1 Power

The drive receives DC power through the same connector that contains the signal lines. Pin assignments for power and ground may be found in Figure 7-3 and Table 7-3.

6.2 Grounding

Provision for tying the DC logic ground and the chassis ground together or for separating these two grounds is vendor specific.

Agreeable locations of the chassis ground are shown in Figure 7-1.

7. 1.8" disk drive Form Factor

Figure 7-1 and Table 7-1 define the dimensions for one of the 1.8" disk drive form factors.

Figure 7-2 and Table 7-2 define the dimensions for the connector for the 1.8" disk drive defined in this SFF-8120 and shows relationships among the dimensions. Dimensions shown do not include warpage allowances.

Figure 7-3 and Table 7-3 define the pin assignment in the connector for the 1.8" disk drive defined in this SFF-8120.

8. Host Connector for 1.8" disk drives

DDK Ltd. part number MCD-D50PA-X or equivalent. Figure 8-1 and Table 8-1 define the dimensions for the host connector for the 1.8" disk drive defined in this SFF-8120.

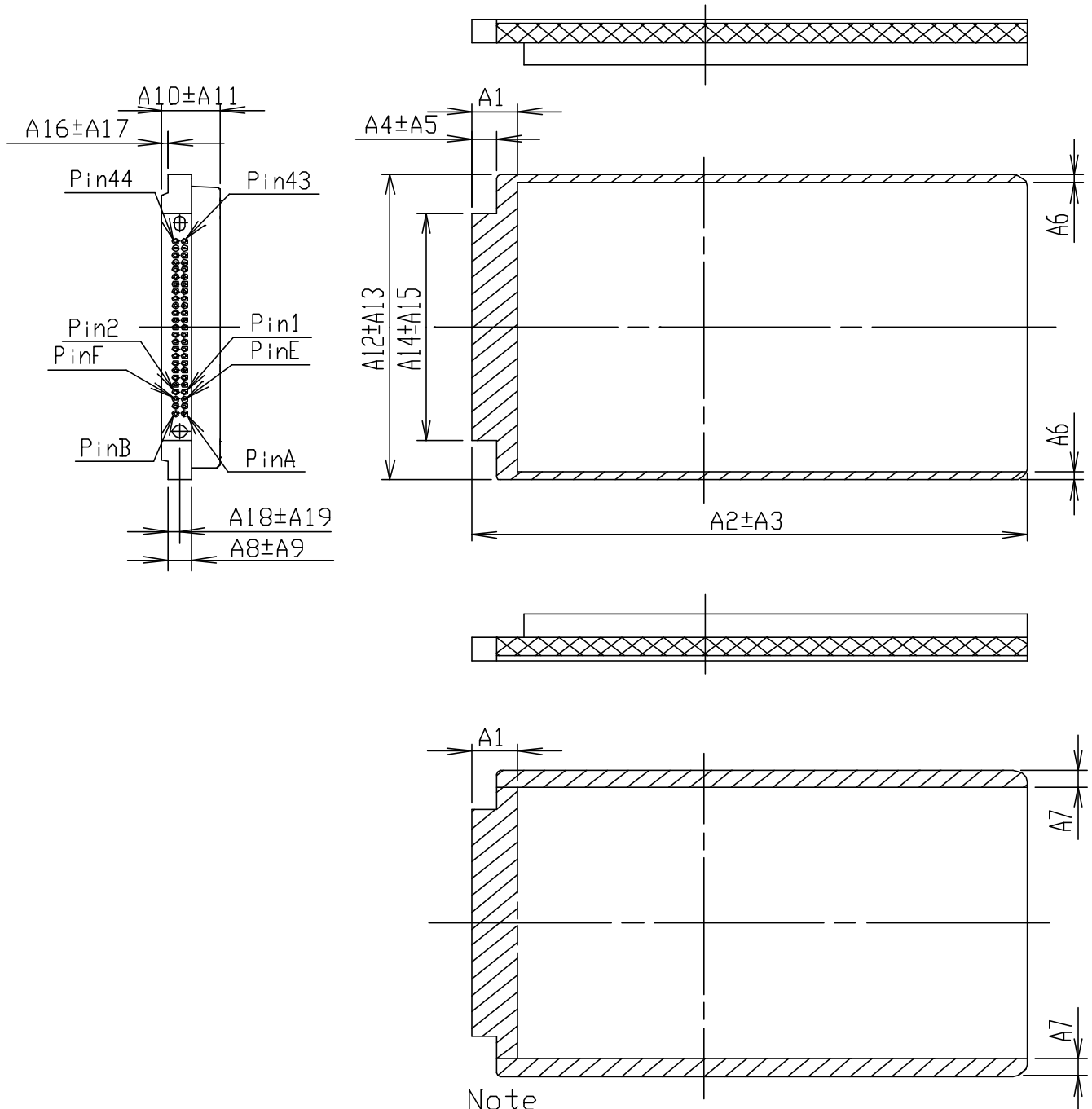

Note

- : Interconnect or Mounting Area
- & : Grounding Area

FIGURE 7-1

TABLE 7-1

Dimension	Millimeters	Inches
A1	*6.5	*0.256
A2	78.5	3.091
A3	0.3	0.012
A4	3.5	0.138
A5	0.2	0.008
A6	*1.5	*0.059
A7	*1.5	*0.059
A8	3.3	0.130
A9	0.15	0.006
A10	5 or 8	0.197 or 0.315
A11	0.15	0.006
A12	54	2.126
A13	0.2	0.008
A14	40	1.575
A15	0.2	0.008
A16	0.85	0.033
A17	0.2	0.008
A18	1.65	0.065
A19	0.1	0.004

* : Minimum Dimension

Warpage Dimensions

Interconnect Area: Width (short side) 0.15mm max/Length(long side) 0.35mm max

Substrate Area: 5.35 or 8.35mm max (device thickness including warpage)

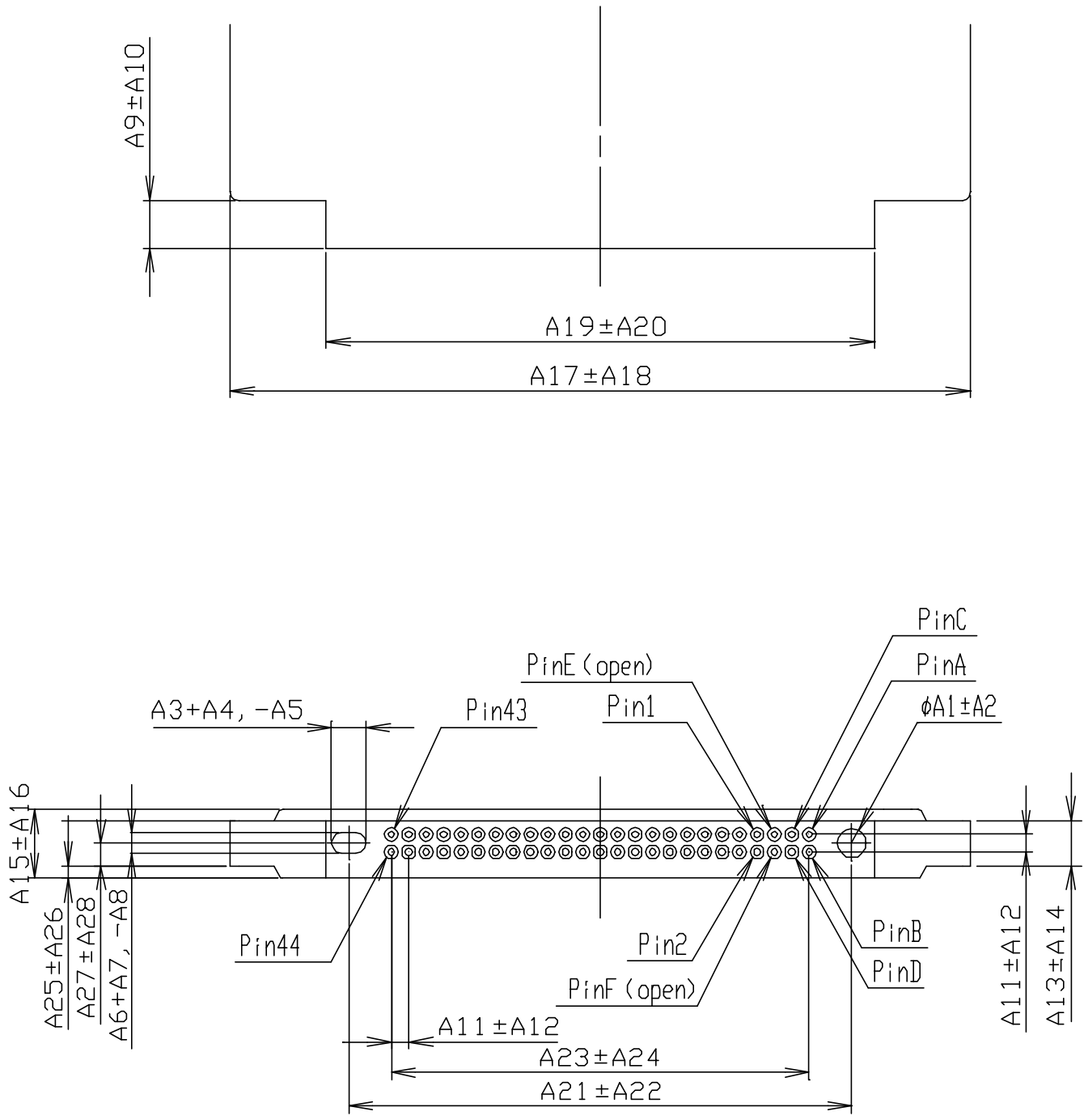

FIGURE 7-2

TABLE 7-2

Dimension	Millimeters	Inches
A1	2.1	0.083
A2	0.05	0.002
A3	2.5	0.098
A4	0.1	0.004
A5	0	0
A6	1.5	0.059
A7	0.1	0.004
A8	0	0
A9	3.5	0.138
A10	0.2	0.008
A11	1.27	0.050
A12	0.15	0.006
A13	3.3	0.130
A14	0.15	0.006
A15	5 or 8	0.197 or 0.315
A16	0.15	0.006
A17	54	2.126
A18	0.2	0.008
A19	40	1.575
A20	0.2	0.008
A21	36.7	1.445
A22	0.15	0.006
A23	30.48	1.200
A24	0.15	0.006
A25	0.85	0.033
A26	0.2	0.008
A27	1.65	0.065
A28	0.1	0.004

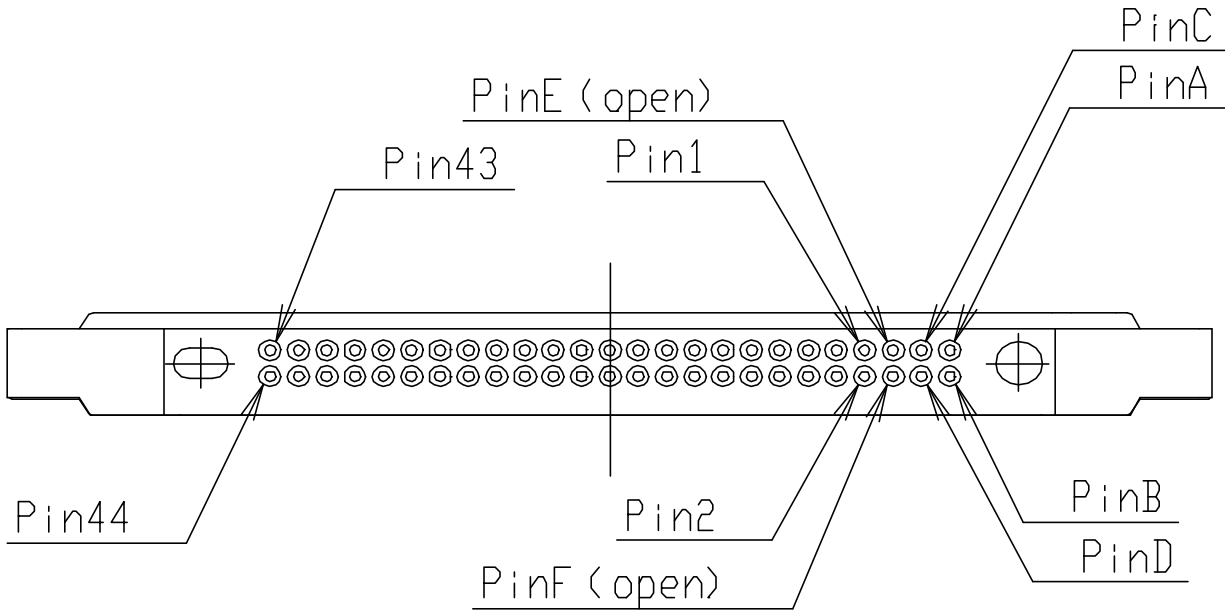

FIGURE 7-3

TABLE 7-3

PIN No.	SIGNALS	PIN No.	SIGNALS
1	RESET-	2	GROUND
3	DD 7	4	DD 8
5	DD 6	6	DD 9
7	DD 5	8	DD 10
9	DD 4	10	DD 11
11	DD 3	12	DD 12
13	DD 2	14	DD 13
15	DD 1	16	DD 14
17	DD 0	18	DD 15
19	GROUND	20	OPEN
21	DMARQ	22	GROUND
23	-DIOW/STOP	24	GROUND
25	-DIOR/HDMARDY-HSTROBE	26	GROUND
27	IORDY/DDMARDY-/DSTROBE	28	CSEL
29	DMACK-	30	GROUND
31	INTRQ	32	IOCS16-
33	DA 1	34	PDIAG-/CBLID-
35	DA 0	36	DA 2
37	CS0-	38	CS1-
39	DASP-	40	GROUND
41	+3.3V (LOGIC)	42	+3.3V (MOTOR)
43	GROUND	44	RESERVED

Note: Symbol (-) in front of signal name shows negative logic.

Some devices may utilize pins A, B, C and D for option selection. If a device uses pins A, B, C and D for device selection, when no jumper is present, the device should be designated as Device 0. When a jumper is present between pins C and D, the device should be designated as Device 1. When a jumper is present between pins B and D, the

device should respond to the CSEL signal to determine the device number.

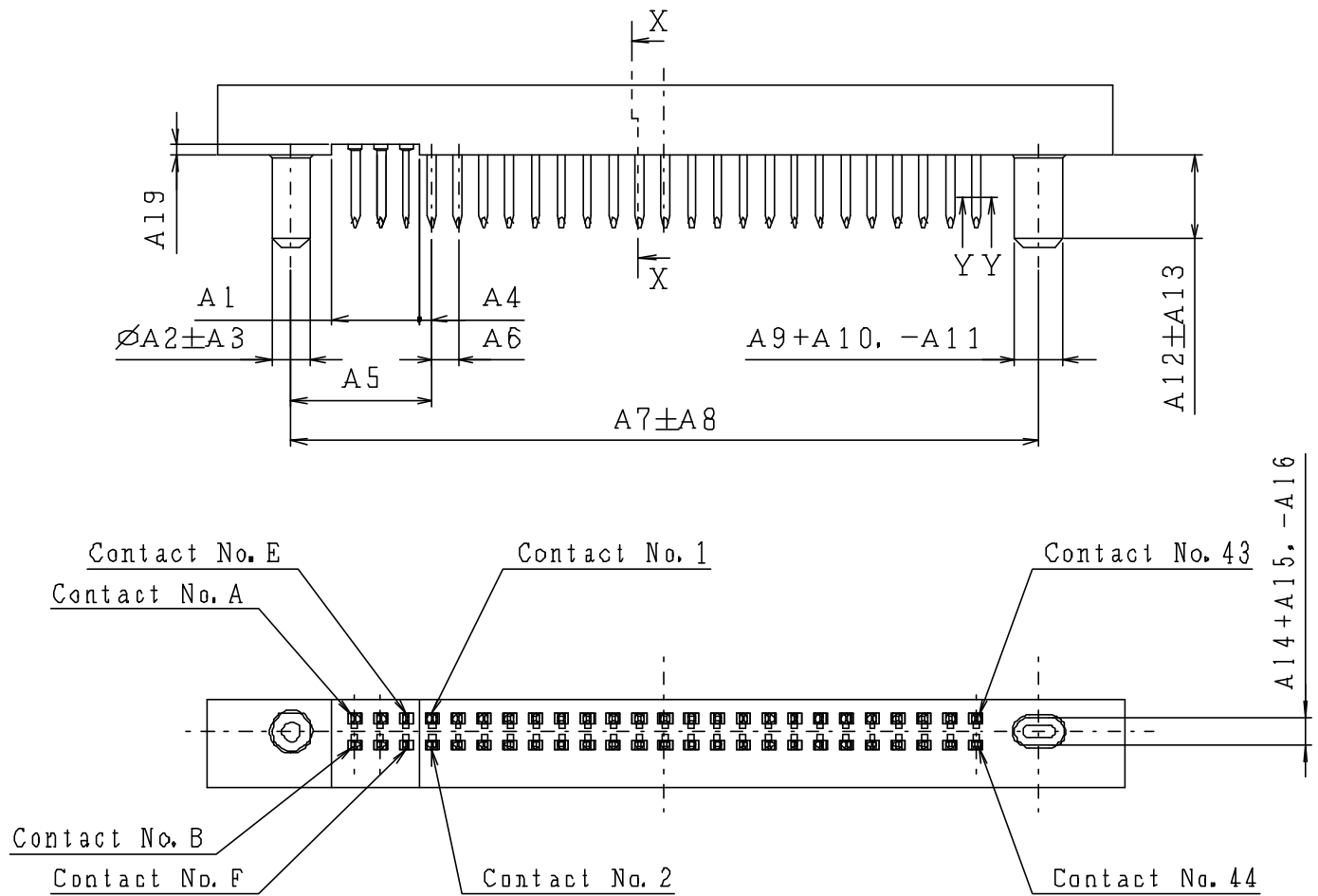

FIGURE 8-1

TABLE 8-1

Dimension	Millimeters	Inches
A1	4.31	0.170
A2	1.9	0.075
A3	0.05	0.002
A4	0.635	0.025
A5	6.92	0.272
A6	1.27	0.050
A7	36.7	1.445
A8	0.1	0.004
A9	2.3	0.091
A10	0	0
A11	0.1	0.004
A12	4.5	0.177
A13	0.1	0.004
A14	1.40	0.055
A15	0	0
A16	0.1	0.004
A17	3.5	0.138
A18	1.27	0.050
A19	0.6	0.024
A20	#0.46	#0.018
A21	0.44	0.017
A22	0.02	0.001
A23	*110 (degree)	*110 (degree)

* = Minimum Dimension # = Maximum Dimension