

SFF Committee documentation may be purchased in electronic form.
SFF specifications are available at <ftp://ftp.seagate.com/sff>

SFF Committee

SFF-8638

Specification for

Multifunction 6X 24 Gb/s Unshielded Connector

Rev 1.1 March 27, 2015

Secretariat: SFF Committee

Abstract: This specification defines the general requirements of a six lane, high speed (up to 24 Gb/s per lane) multifunction plug and receptacle connector that is designed for use as a common connector system. The dimensioning for the six lane multifunction connector allows compatibility between unshielded dual port serial attachment connectors that have been developed in accordance with SFF-8482 and SFF-8680, and unshielded multiport serial attachment connectors that have been developed in accordance with SFF-8630.

Systems utilizing this connector may support single port SATA, dual port SATA Express, dual port SAS, MultiLink SAS, or up to four (4) port PCIe device configurations in an isolated manner. Systems utilizing the six lane receptacle in a backplane application will accept devices with plugs developed in accordance with SFF-8482, SFF-8630, and SFF-8680.

This specification provides a common reference for systems manufacturers, system integrators, and suppliers. This is an internal working specification of the SFF Committee, an industry ad hoc group.

This specification is made available for public review, and written comments are solicited from readers. Comments received by the members will be considered for inclusion in future revisions of this specification.

The description of a connector in this specification does not assure that the specific component is actually available from connector suppliers. If such a connector is supplied it must comply with this specification to achieve interoperability between suppliers.

Support: This specification is supported by the identified member companies of the SFF Committee.

POINTS OF CONTACT:

Bill Lynn
Dell
One Dell Way, RR5-30
Round Rock, TX 78682
Ph: 512-723-5528
William_Lynn@Dell.com

Fred A. Fons
Foxconn Electronics, Inc
100 South 38th Street
Harrisburg, PA 17111
Phone: 717-558-7518x141
fred.fons@FIT-Foxconn.com

I. Dal Allan
Chairman SFF Committee
14426 Black Walnut Ct
Saratoga, CA 95070
Ph: 408-867-6630
endlcom@acm.org

EXPRESSION OF SUPPORT BY MANUFACTURERS

The following member companies of the SFF Committee voted in favor of this industry specification.

Amphenol
FCI
Foxconn
GLNet Electronics
Hewlett Packard
HGST
Seagate
Sichuan
TE Connectivity

The following member companies of the SFF Committee voted to abstain on this industry specification.

Arista
Broadcom
EMC
Finisar
JDS Uniphase
Sumitomo

The user's attention is called to the possibility that implementation to this Specification may require use of an invention covered by patent rights. By distribution of this specification, no position is taken with respect to the validity of a claim or claims or of any patent rights in connection therewith. Members of the SFF Committee which advise that a patent exists are required to provide a statement of willingness to grant a license under these rights on reasonable and non-discriminatory terms and conditions to applicants desiring to obtain such a license.

Change History

Revision 1.0

- Source of SFF-8637 Rev 2.0 as modified for 24 Gb/s operation

Revision 1.1

- Removed sentence about cables in the Scope and Section 4.2.

Foreword

The development work on this specification was done by the SFF Committee, an industry group. The membership of the committee since its formation in August 1990 has included a mix of companies which are leaders across the industry.

When 2 1/2" diameter disk drives were introduced, there was no commonality on external dimensions e.g. physical size, mounting locations, connector type, connector location, between vendors.

The first use of these disk drives was in specific applications such as laptop portable computers and system integrators worked individually with vendors to develop the packaging. The result was wide diversity, and incompatibility.

The problems faced by integrators, device suppliers, and component suppliers led to the formation of the SFF Committee as an industry ad hoc group to address the marketing and engineering considerations of the emerging new technology.

During the development of the form factor definitions, other activities were suggested because participants in the SFF Committee faced more problems than the physical form factors of disk drives. In November 1992, the charter was expanded to address any issues of general interest and concern to the storage industry. The SFF Committee became a forum for resolving industry issues that are either not addressed by the standards process or need an immediate solution.

Those companies which have agreed to support a specification are identified in the first pages of each SFF Specification. Industry consensus is not an essential requirement to publish an SFF Specification because it is recognized that in an emerging product area, there is room for more than one approach. By making the documentation on competing proposals available, an integrator can examine the alternatives available and select the product that is felt to be most suitable.

SFF Committee meetings are held during T10 weeks (see www.t10.org), and Specific Subject Working Groups are held at the convenience of the participants. Material presented at SFF Committee meetings becomes public domain, and there are no restrictions on the open mailing of material presented at committee meetings.

Most of the specifications developed by the SFF Committee have either been incorporated into standards or adopted as standards by EIA (Electronic Industries Association), ANSI (American National Standards Institute) and IEC (International Electrotechnical Commission).

If you are interested in participating or wish to follow the activities of the SFF Committee, the signup for membership and/or documentation can be found at:
www.sffcommittee.com/ie/join.html

The complete list of SFF Specifications which have been completed or are currently being worked on by the SFF Committee can be found at:
<ftp://ftp.seagate.com/sff/SFF-8000.TXT>

If you wish to know more about the SFF Committee, the principles which guide the activities can be found at:
<ftp://ftp.seagate.com/sff/SFF-8032.TXT>

Suggestions for improvement of this specification will be welcome. They should be sent to the SFF Committee, 14426 Black Walnut Ct, Saratoga, CA 95070.

TABLE OF CONTENTS

1. Scope	5
1.1 Application Specific Criteria	5
2. References	5
2.1 Industry Documents	5
2.2 SFF Specifications	6
2.3 Sources	6
2.4 Conventions	6
3. General Description	7
4. Overview of Referenced Specifications	7
4.1 Application Requirements	7
4.2 SFF-8639	7

FIGURES

Figure 3-1 Documentation to Implement a 24 Gb/s Connector	7
Figure 4-1 Receptacle View	8
Figure 4-2 Plug View	8

SFF Committee --

Multifunction 6X 24 Gb/s Unshielded Connector

1. Scope

This specification defines the terminology and mechanical requirements for a six lane, high speed (up to 24 Gb/s per lane) plug and receptacle that is designed for use as a common connector system supporting SATA, SAS and PCIe based devices. The mechanical dimensioning and signal assignments for the six lane common connector receptacle allows intermateability with the unshielded dual port serial attachment plug connectors that have been developed in accordance with SFF-8482 and SFF-8680, and unshielded multiport serial attachment connectors that have been developed in accordance with SFF-8630.

1.1 Application Specific Criteria

This connector shall meet the 24 Gb/s electrical performance requirements defined by SAS-3 (Serial Attached SCSI - 3) and intermates with previous generations of lower speed SAS connectors.

Both SAS and PCIe define respective requirements for the transmission of multi-gigabit signals on a backplane. When this connector is used in either of these applications, its performance shall meet the requirements of the appropriate standard.

2. References

2.1 Industry Documents

The following documentation is relevant to this Specification.

PCI Express® Specifications are available from <http://www.pcisig.com>.

- PCI Express specification, revision 2.1
- PCI Express specification, revision 3.0
- PCI Express® Card Electromechanical Specification, Revision 2.0. April 11, 2007
Commonly known as the "PCIe CEM" specification

Serial ATA International Organization

- Serial ATA Revision 3.1 (SATA)

T10

- INCITS 376-2003 SAS (Serial Attached SCSI)
- INCITS 417-2006 SAS 1.1 (Serial Attached SCSI 1.1)
- INCITS 457-2010 SAS 2 (Serial Attached SCSI 2)
- INCITS 478-2011 SAS 2.1 (Serial Attached SCSI 2.1)
- INCITS 519-2014 SAS 3 (Serial Attached SCSI 3)
- INCITS 534 SAS 4 (Serial Attached SCSI 4)

SFF Committee specifications are available from <ftp://ftp.seagate.com/sff>

- SFF-8482 Serial Attachment 2X Unshielded Connector
Commonly known as the "SAS connector" specification
Note: SFF-8482 has been standardized as EIA-966
- SFF-8223 2.5" Drive Form Factor with Serial Attached Connector
Commonly known as the "2.5 inch drive" specification.
Note: SFF-8223 has been standardized in EIA-720
- SFF-8630 Serial Attachment 4X Unshielded Connector
Commonly known as SAS MultiLink)
- SFF-8639 Multifunction 6X Unshielded Connector

- SFF-8680 Serial Attachment 2X Unshielded Connector
Commonly known as the high speed version of SFF-8482
- SFF-9639 Multifunction 6X Unshielded Connector Pinouts

2.2 SFF Specifications

There are several projects active within the SFF Committee. The complete list of specifications which have been completed or are still being worked on are listed in the specification at <ftp://ftp.seagate.com/sff/SFF-8000.TXT>

2.3 Sources

Those who join the SFF Committee as an Observer or Member receive electronic copies of the minutes and SFF specifications (<http://www.sffcommittee.com/ie/join.html>).

Copies of ANSI standards may be purchased from the InterNational Committee for Information Technology Standards (<http://www.techstreet.com/incitsgate.tmp>).

2.4 Conventions

The ISO convention of numbering is used i.e., the thousands and higher multiples are separated by a space and a period is used as the decimal point. This is equivalent to the English/American convention of a comma and a period.

American	French	ISO
0.6	0,6	0.6
1,000	1 000	1 000
1,323,462.9	1 323 462,9	1 323 462.9

3. General Description

This specification identifies the documentation required to implement a 24 Gb/s Multifunction Unshielded connector suitable to the using applications, as illustrated in the following pictorial representation.

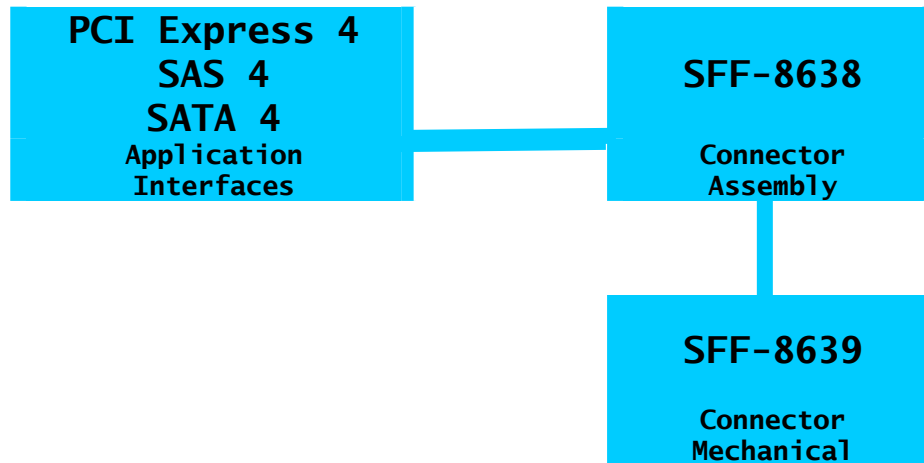

FIGURE 3-1 DOCUMENTATION TO IMPLEMENT A 24 GB/S CONNECTOR

4. Overview of Referenced Specifications

4.1 Application Requirements

The electrical and EMI considerations for the use of this connector are specified by the using standards listed in Section 1.1.

4.2 SFF-8639

The mechanical dimensioning of this specification provides mechanical compatibility between generations of various speeds.

This connector system is designed to allow devices that support single port SATA, dual port SATA Express, dual port SAS, MultiLink SAS, or up to four (4) port PCIe port plugs to mate to a common fixed receptacle that is mechanically compatible to the connector receptacles designed in accordance with SFF-8482, SFF-8630, or SFF-8680.

The interface supports all of the contact sets defined by a dual port SAS implementation plus an additional 39 signals. The additional 39 signals are used to support 4 lanes of PCIe plus 10 sideband signals. In a MultiLink SAS implementation 14 of the 39 signals are used to support the two additional SAS ports.

The mechanical representation of this connector looks the same between generations, however, there may have been changes to the internal design which enable it to perform at the characteristics required of the new applications.

Connectors manufactured to meet these applications can be expected to perform satisfactorily in systems designed for previous generations of lower speed systems, but it is not typically anticipated that they will be able to meet the needs of next generation systems that require higher data rates.

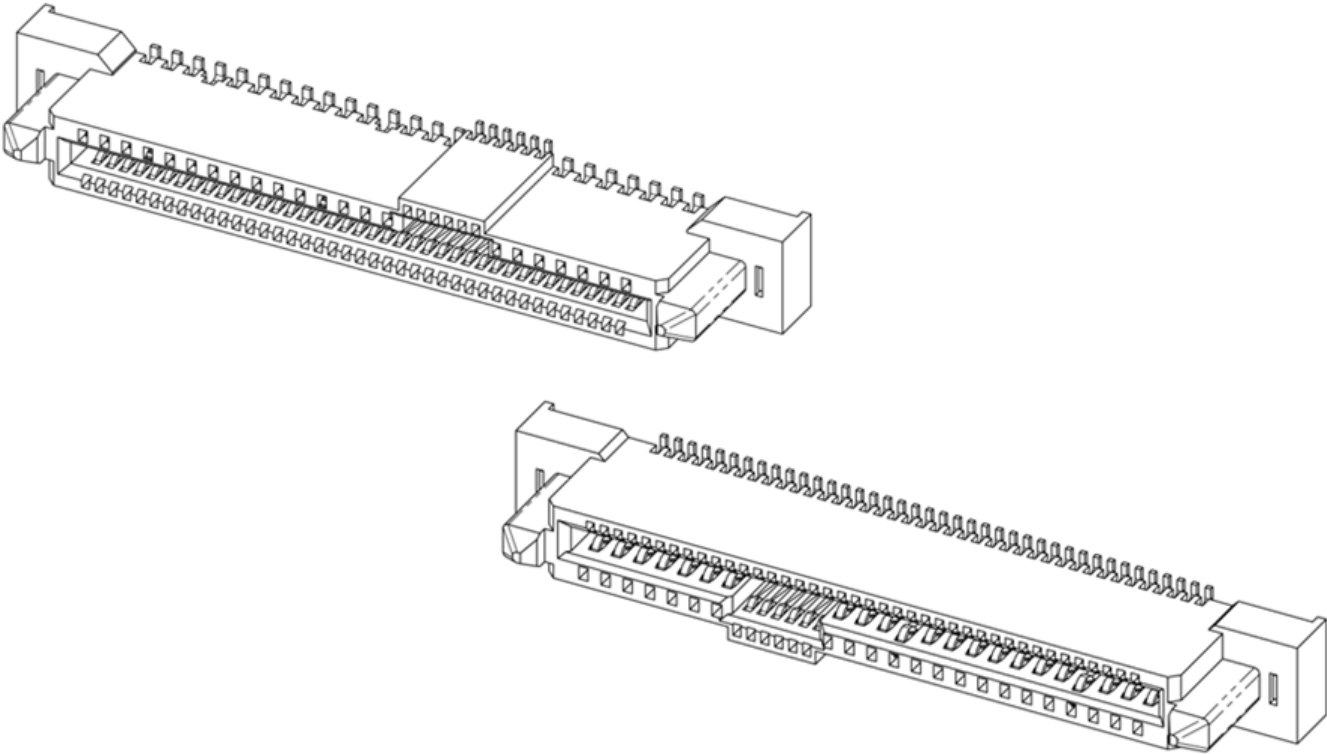

FIGURE 4-1 RECEPTACLE VIEW

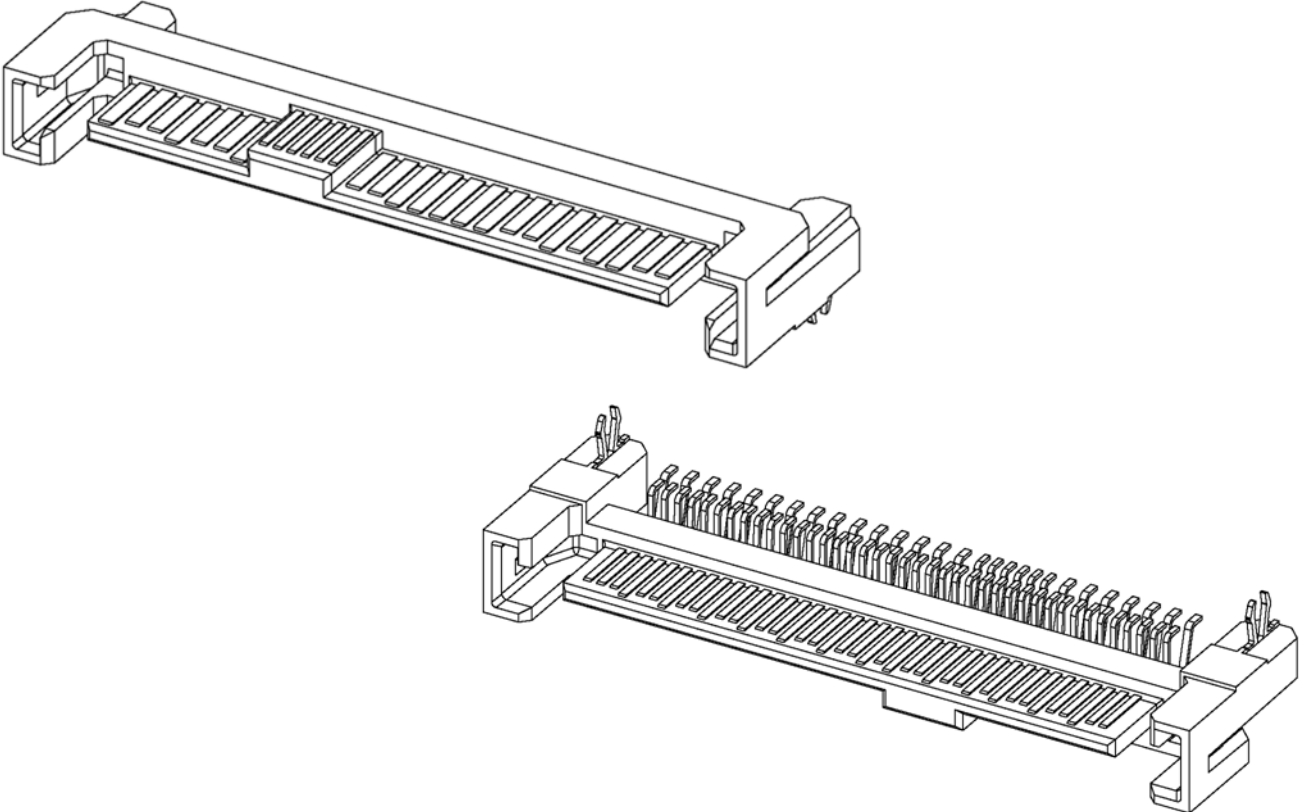

FIGURE 4-2 PLUG VIEW